



**The Menzi Muck M2.
Clever, compact and efficient.**

The new Menzi M2-series. A clever climbing specialist.

M220

- Hydrostatic two wheel drive over the two big wheels
- Two removable shafts with two small steering wheels
- Hydraulic telescopic stabilization



Economical & efficient. Engine, hydraulic, electric and cooling system.

APM - up to 30% fuel savings

The APM controller (Anticipating Power Management) creates a new, fast and harmonic interplay between the motor and the hydraulics. Overloading is thereby reduced to an absolute minimum. Power, Eco and Fine mode provide extra help in efficient operation of the machines.

Deutz-Power

The powerful 4-cylinder Turbo-Diesel engine of Deutz (55 KW / 75 HP) meets the exhaust EU Stage IIIB / US Tier IV and is ready for even stricter upcoming emission limits.

Cooling system

Generously dimensioned cooling system, three separate coordinated cooler elements for hydraulic oil/ charge air/ water, maximum cooling capacity through side-by-side arrangement of the cooling elements, variable fan motor, option: swing condenser-element for air-conditioning.

Options

- automatic central lubrication system
- biodegradable hydraulic oil
- hydraulic partial flow filter
- heavy lifting and road equipment
- hydraulic preparation for winch
- LED-additional light on the boom
- special color
- leakage line
- electrically switchable check valves
- additional safety valves on the dipper cylinder
- lock out switch

Swiveling with big slewing ring

An axial piston motor with automatic multi-disc stop brake acts via a planetary gear on the internal gearing of the large-dimensioned, double-row slewing ring (Ø 1000 mm). The maximum slewing force is available over the entire speed range.

Hydraulic system

Sensitive Load Sensing hydraulic system. The harmonious operating cycle is geared towards smooth and optimised performance. A high pressure piston pump for working and driving, an piston pump for chasis and a gear pump for the fan.

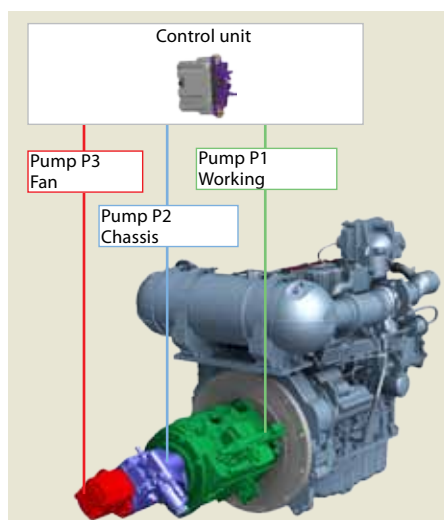

Hydraulic cylinders

All cylinders on the chasis are equipped with check valves for safety. All cylinders on the boom are equipped with cushioning.

Hydraulic circuits

The required liter /gallons quantities of the hydraulic auxiliary circuits can be selected on the color display.

Circuit 1 (on the boom)

up to 150 l/min. - 39.6 US-gall./min. through proportional foot pedal - double acting

Circuit 2 (on the boom)

up to 40 l/min. - 10.6 US-gall./min. through proportional-rocker switch on the right joystick - double acting

Circuit 3 (am Arm)

up to 40 l/min. - 10.6 US-gall./min. s/w on left joystick - double acting

Circuit 4 (on the boom)

for hydraulic quick changer from pilot pressure - double acting

Hydraulic winch preparation (chassis)

up to 100 l/min. - 26.4 US-gall./min. through switch on the left joystick - double acting (option)

Return line (on the boom)

for hydraulic hammer

Leakage line (option)

Menzi Muck the technology leader. Innovations that make us number one.

The M2-Dual-Drive

The new, electronically controlled drive system ensures precise and regular propulsion up to 7 km/h / 5 mph. Depending on the steering angle, distribution of wheel speeds and driving forces are equally and continuously adapted to the driving situation.

The M2 stabilisation

The enormous adjustment range of the M2 chassis creates an excellent balance angle on steep slope.

Proved Menzi powerboom

There is a lot of innovation in the proven and unique boom of the M-series. Unique to Menzi Muck, the boom cylinder is mounted horizontally in the center part. Collisions at the boom cylinder are therefore impossible.

Wide-angle kinematics with power booster

The kinematics of Menzi Muck opens new dimensions: optimum work in the close-up range at the minimum possible swivel radius is contrasted with maximum stretching of the boom. The Menzi power booster thereby supplies the highest possible forces over the whole working range.

Kinematics comparison at the dipper

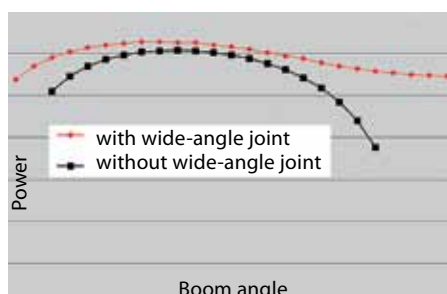

Flying made easy!

In just a few steps, the Menzi Muck M2 can be disassembled for transport by helicopter, funicular or crane to the desired individual sizes. Clever auxiliary equipment facilitate this work enormously.



**menzi
muck**

The panorama cockpit. The operator is most important.

Operators cockpit

A free view of the entire working environment, the support and the wheels, provide the operator with safety and complete control in all situations. The spacious cab provides a perfect sense of space and many practical details for relaxed working.

Comfort and safety

From the ergonomic joystick with proportional rocker and hand support to the air-suspended operator's seat right up to adjustable armrests and foot pedals, no stone has been left unturned to provide the operator with a maximum of comfort.



Color display & control unit

Free adjustable 7-inch color display with integrated control units and memory capacity for various attachments.

Extensive standard equipment

ROPS (Roll-Over-Protection-System) according to DIN ISO 3471, cast parts at the upper structure used as fenders, side and rear covers are opened supported by gas-pressure springs, diesel fuel pump with auto stop, integrated tool box, DAB+ radio with CD/MP3-player, powerful heating with six individual adjustable air nozzles, pollen and recirculated air filter, 4 LED-spotlights (2 in the front, 2 in the rear), etc.

Numerous cab options

Air-conditioning, heater with time clock, rotating beacon, four point safety harness



The Menzi Muck M2.

It`s technical data say it all.



Lifting capacity @ 3.0 m	max. 5400 kg	11905 lb
Lifting capacity@ 4.5 m	max. 3100 kg	6834 lb
Lifting capacity@ 6.0 m	max. 2000 kg	4409 lb
Breakout force	75 kN	7648 kp
Ripping force	43 kN	4385 kp

Weight without accessories	7000 kg	15432 lb
Turning radius	6800 mm	22'3"
Speed	7 km/h	5 mph
Steering wheels	12.5/60-15 / 20 Ply	
Hub drive	500/45-20 / 16 Ply	
Operating tank	125 liters	33.0 US-gall.
Additional tank in the chassis	210 liters	55.5 US-gall.
Content of hydr. system	190 liters	50.2 US-gall.

Dimensions without PowerTilt. Technical data vary upon tyre/tool

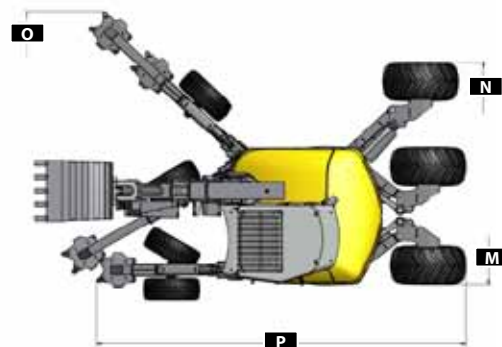
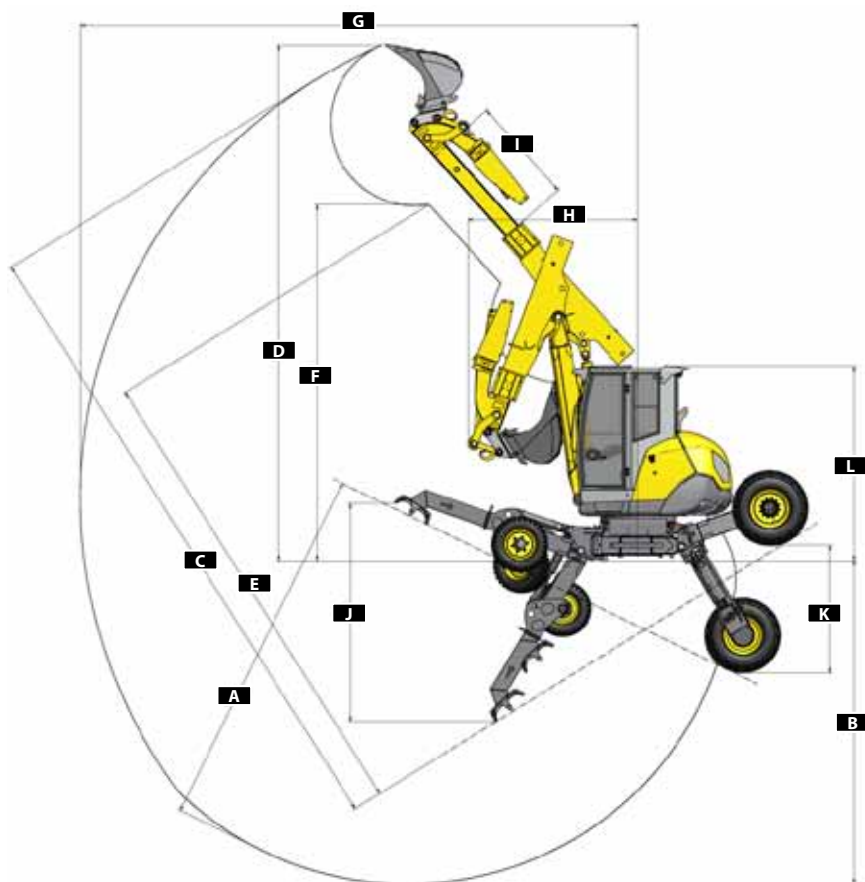

Dimensions in mm / "		Menzi Muck M220	
A	Max. Excavation depth with adjusted chassis	4790	15'8"
B	Max. Excavation depth chassis horizontal	4250	13'11"
C	Max. Excavation height with adjusted chassis	8400	27'6"
D	Max. Excavation height chassis horizontal	6780	22'2"
E	Max. Discharge height with adjusted chassis	6220	20'4"
F	Max. Discharge height chassis horizontal	4680	15'4"
G	Max. Jib Range	7220	23'8"
H	Min. Swivelling radius	2200	7'2"
I	Dipper length	1400	4'7"
J	Positioning range stabilizers	2870	9'4"
K	Positioning range hub drive	1680	5'6"
L	Transport height	2550	8'4"
M	Minimum width hub drive, transport width	1810	5'11"
N	Max. positioning width hub drive	4040	13'3"
O	Max. positioning width stabilizers	5360	17'7"
P	Chassis length	4780	15'8"

More information.



www.menzimuck.com

- entire product range
- distributors, service network and event calendar
- company infos
- calendar of trade fairs and open doors
- fanshop
- multimedia (brochures, guides, photographs, videos, ...)
- multilingual
- and much more



facebook

www.facebook.com/menzimuck.com

- the history of the Menzi Muck
- product and company news
- discussions over the Menzi Muck
- events
- contributions from other Menzi Muck operators and fans



You Tube

www.youtube.com/menzimuck.com

- events and special reports
- TV-reports
- Menzi Muck working
- accessories in action